

# SCANIA

SPECIFICATION

**P-, G- and R-series**

## P 230 DB6x2\*4MNB

27000Kg GVW

THREE AXLE REFUSE CHASSIS  
(REAR STEER)

# P

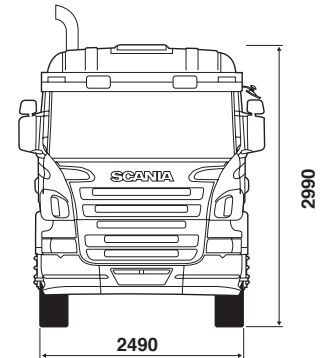
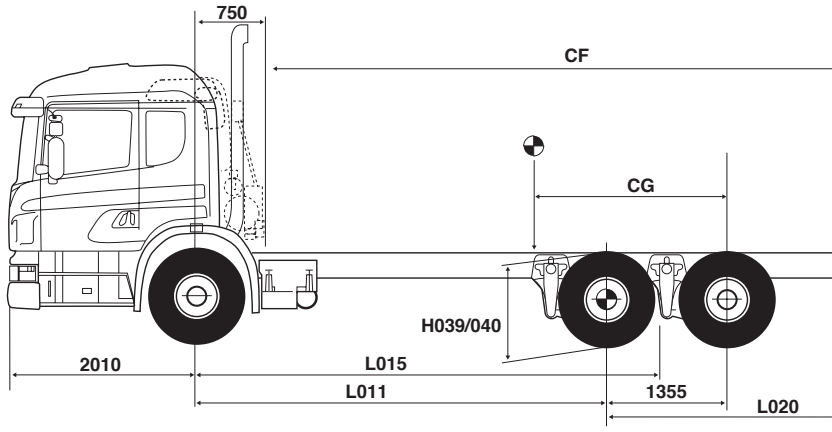

### DIMENSIONS (mm)

	3900	4100	4300	4500	4700	4900	5100	5300	5500	5700	5900	6100
L011	3900	4100	4300	4500	4700	4900	5100	5300	5500	5700	5900	6100
L015	4438	4638	4838	5038	5238	5438	5638	5838	6038	6238	6438	6638
CF	5750	5950	6150	6350	6550	6750	6950	7150	7350	7550	7750	7950
L020	2600	2600	2600	2600	2600	2600	2600	2600	2600	2600	2600	2600
L020 Max	4000	4200	4200	4400	4600	4800	5000	5200	5200	5000	4800	4600
CG Max	1506	1535	1563	1591	1619	1646	1674	1701	1728	1755	1782	1764
CG Min	1262	1279	1296	1312	1329	1345	1361	1377	1393	1408	1424	1387

H039 unladen	H040 laden	Chassis Height
1012 mm	985 mm	Normal (N)

CG dimension for body and payload calculated for standard model at standard GB plated weights. Height dimensions measured to top of frame at rear bogie centreline. Rear overhang (L020) can be specified in 10 mm steps up to maximum – check legality.

### PLATED WEIGHTS – AWR

		Front Axle	Drive Axle	Trailing Axle	GVW	GTW
Design						
Gross	Kg	8000	11500	7500	27000	30500
Legal						
Max in GB	Kg	8000	11500	7500	26000	29500

Plated weights dependent on statutory tyre limitations.

### CHASSIS/CAB WEIGHTS

(Tolerance +/- 2.5%)

Axle distance	Front	Rear Bogie	Total (kg)
3900	4996	2639	7635
4100	5005	2645	7650
4300	5014	2651	7665
4500	5023	2657	7680
4700	5032	2663	7695
4900	5041	2669	7710
5100	5050	2675	7725
5300	5059	2681	7740
5500	5068	2687	7755
5700	5077	2693	7770
5900	5086	2699	7785
6100	5266	2884	8150

Chassis cab weight includes 20 litres of fuel, oil and water. Driver not included. See overleaf for option weights.

## ENGINE (EURO 5)

Scania '9 litre' vertical five cylinder in-line turbocharged intercooled direct injection diesel with Scania XPI.

**'230'**

**Type:** DC9-39  
**Swept Volume:** 9.3 litres  
**Bore:** 130 mm  
**Stroke:** 140 mm  
**Compression Ratio:** 17:1  
**\*Max. Power:** 169kW (230 h.p.) at 1900 rev/min  
**\*Max. Torque:** 1050 Nm (774 lbf.ft) between 1000 and 1500 rev/min

**Engine Management System:** EMS incorporating Cruise Control and speed limiter

**Emission Control:** Scania EGR

**Cooling:** Water cooled with rubber mounted 2 row radiator and electronically regulated fan

**Coolant Capacity:** 42 litres

**Oil Capacity:** 31 litres

**Air Cleaner:** Dry replaceable paper element

**Engine driven PTO provision:** ED120

### Options:-

**(1) Details as above except for the following:-**

**'280'**

**Type:** DC9-38  
**\*Max. Power:** 206kW (280 h.p.) at 1900 rev/min  
**\*Max. Torque:** 1400 Nm (1033 lbf.ft) between 1000 and 1350 rev/min

**(2) Details as above except for the following:-**

**'320'**

**Type:** DC9-37  
**\*Max. Power:** 235kW (320 h.p.) at 1900 rev/min  
**\*Max. Torque:** 1600 Nm (1180 lbf.ft) between 1100 and 1200 rev/min

**(3) Details as above but engines fitted with Diesel Particulate Filters and EEV certified:- '230' DC9-30, '280' DC9-29, '320' DC9-32**

\*With fan at max. slip

## GEARBOX

**Type:** Scania GA765 – (Allison 3000) with 8 o'clock P.T.O. output. Automatic 6 speed electronically controlled. – '230' engine.

**Type:** Scania GA766 – (Allison 3200) with 8 o'clock P.T.O. output. Automatic 6 speed electronically controlled. – '280' engine.

**Type:** Scania GA866 – (Allison 4000) with 1 o'clock P.T.O. output. Automatic 6 speed electronically controlled. – '320' engine.

## REAR AXLE

**Type:** **Drive:** Scania ADA1300  
**Trailing:** Scania ARA900

**Capacity:** Combined 19000 Kg  
Pressed steel housing with magnetic oil drain plug.

## REAR AXLE GEAR

**Type:** Scania R660  
Single reduction hypoid.Crown wheel and pinion matched during manufacture.Pneumatically operated differential lock.

## FRONT AXLE

**Type:** Scania AMA860  
**Capacity:** 8000Kg

## STEERING

**Type:** Recirculating ball. Hydraulically assisted power steering to first and last axle.  
**Steering wheel:** Diameter 450mm. Lock to lock 4.9 turns  
**Turning circle:** Kerb to kerb  
3.9m A/D 14.2m 4.1m A/D 14.9m 4.3m A/D 15.6m  
4.5m A/D 16.4m 4.7m A/D 17.1m 4.9m A/D 17.8m  
5.1m A/D 18.5m 5.3m A/D 19.2m 5.5m A/D 19.9m  
5.7m A/D 20.6m 5.9m A/D 21.3m 6.1m A/D 22.1m

## SUSPENSION

**Type Front:** Two bag air with axle located by tie rods. Front anti-roll bar.  
**Type Rear:** Quarter elliptic with air bellows on both axles. Pneumatic tag-axle hoist. Chassis height may be raised or lowered to assist loading. Double acting telescopic shock absorbers are fitted to all axles.

## WHEELS & TYRES

**Front:** 9.00 x 22.5 ten stud spigot mounted disc wheels fitted with 315/80R22.5 radial tubeless tyres (2).  
**Drive:** 9.00 ten stud spigot mounted disc wheels fitted with 315/80R22.5 radial tubeless tyres (4).  
**Rear:** 9.00 ten stud spigot mounted disc wheels fitted with 315/80R22.5 radial tubeless tyres (2).

### Options:-

- (1) 11.75 x 22.5 wheels with 385/65R22.5 or 385/55R22.5 tyres - steered axles only.**
- (2) Aluminium wheels - machined or polished surface finish.**
- (3) Wheel embellishers - steered axles only.**

## FRAME

**Type:** F950-50 – 3.9 to 5.9m A/D  
F958-50 for 6.1m A/D and all 'H' duty class.

Flat top constant depth 'U' channel with riveted crossmembers

### Sidemember Dimensions:

F950 – 270 x 90 x 9.5mm  
F958 – 270 x 90 x 9.5mm External member  
– 247 x 78 x 8mm Internal member

Pre-drilled for bodywork mounting brackets.

Width over parallel section of frame = 770mm

**Bumper:** Aerodynamic incorporating FUP

## BRAKE SYSTEM

**Type:** Ventilated disc brakes on all axles. Dual circuit, full air, EC brake system incorporating Category 1 ABS and Traction Control. Electronic signalling with pneumatic back-up. Pad wear indicator. Brake pipes manufactured from either rust protected steel or high impact synthetics

**Service Circuit:** Actuates all truck brakes

**Secondary Circuit:** First position of park brake lever actuates spring brakes.

**Parking Brake:** Actuates spring chambers on drive and last axles.

**Exhaust Brake:** Air actuated operated by foot switch

**Brake Antifreeze Protection:** Air dryer

**Brake Wear Adjusters:** Automatic

### Options:-

- (1) Gearbox integral retarder**

## BRAKE DIMENSIONS

<b>Pad lining area:</b>	2 x 190cm <sup>2</sup> on all axles
<b>Swept area of each disc:</b>	2 x 940cm <sup>2</sup>

## ELECTRICAL SYSTEM

<b>Type:</b>	24V neg (-ve) earth	<b>Alternator:</b>	100A
<b>Batteries:</b>	Twin 140Ah		
Rear H.I. lamps, Reversing lights, Battery connection - 200A			

### Options:-

- (1)** 180Ah batteries, **(2)** 225Ah batteries,  
**(3)** Bodywork electrical preparation – see separate document.

## FUEL TANK

1 x 300 litre steel RHS

### Options:- (Minimum axle distance and suspension type in brackets)

	RH Side	LH Side	RH Side	LH Side
<b>Steel - G</b>	150	150	200	200
	200		300	
	300	300	350	350
	450	450	400	400
			500	500
			600	600
			700	700 (4100)

Tank sizes can be supplied in LH + RH combinations of the above but steel and aluminium cannot be mixed. Sides viewed from rear.

## GENERAL EQUIPMENT

Front tow pin.

Vertical exhaust outlet.

## INSTRUMENTS & CONTROLS

Two man, one day, EC digital tachograph, rev-counter and gauges for coolant temperature and fuel. Central display for vehicle information and warning messages. Six speed wipers with four jet integral screen wash. Halogen headlamps adjustable from cab for correction of beam height. Warning lights for all major systems grouped within easy vision.

Instrument panel of modular design with switches and controls grouped according to usage. All instruments are back-lit and non-reflective. Impact absorbing, adjustable steering wheel with column lock.

## CAB

### CP19E – Municipal Cab

Four man, easy access walk-through safety cab. Individual driver and passenger seats plus two man bench seat. 3 point set belts for all seats. Electrically operated driver and passenger windows. Rear wall storage modules plus wet weather clothes hanging facility.

## P.T.O. OPTIONS

**EG112:** 1.17:1 Propshaft output – GA765/6

**EG210:** 1.08:1 Propshaft output – GA866

## WEIGHTS FOR OPTIONAL EQUIPMENT IN KILOGRAMS (Front – Rear – Total)

Axle Distance	39	41	43	45	47	49	51	53	55	57	59	61
*280/GA766	+98 +13 +111	+98 +13 +111	+100 +11 +111	+100 +11 +111	+101 +10 +111	+101 +10 +111	+102 +9 +111	+102 +9 +111	+103 +8 +111	+103 +8 +111	+104 +7 +111	+104 +7 +111
*320/GA866	+112 +35 +147	+112 +35 +147	+114 +33 +147	+114 +33 +147	+115 +32 +147	+115 +32 +147	+116 +31 +147	+116 +31 +147	+117 +30 +147	+117 +30 +147	+118 +29 +147	+118 +29 +147
385/55 tyres/ 11.75 rims	+30 +30 +60	+30 +30 +60	+30 +30 +60	+30 +30 +60	+30 +30 +60	+30 +30 +60	+30 +30 +60	+30 +30 +60	+30 +30 +60	+30 +30 +60	+30 +30 +60	+30 +30 +60
385/65 tyres/ 11.75 rims	+38 +38 +76	+38 +38 +76	+38 +38 +76	+38 +38 +76	+38 +38 +76	+38 +38 +76	+38 +38 +76	+38 +38 +76	+38 +38 +76	+38 +38 +76	+38 +38 +76	+38 +38 +76
Aluminium Wheels												
9.00x22.5	-30 -90 -120	-30 -90 -120	-30 -90 -120	-30 -90 -120	-30 -90 -120	-30 -90 -120	-30 -90 -120	-30 -90 -120	-30 -90 -120	-30 -90 -120	-30 -90 -120	-30 -90 -120
11.75x22.5	-44 -44 -88	-44 -44 -88	-44 -44 -88	-44 -44 -88	-44 -44 -88	-44 -44 -88	-44 -44 -88	-44 -44 -88	-44 -44 -88	-44 -44 -88	-44 -44 -88	-44 -44 -88
F958-50 frame	+105 +190 +295	+105 +190 +295	+110 +195 +305	+110 +195 +305	+115 +195 +310	+120 +200 +320	+130 +200 +330	+130 +210 +340	+140 +210 +350	+140 +220 +360	+150 +220 +370	Std.
Retarder	+22 +8 +30	+23 +7 +30	+24 +6 +30	+24 +6 +30	+24 +6 +30	+24 +6 +30	+24 +6 +30	+24 +6 +30	+25 +5 +30	+25 +5 +30	+25 +5 +30	+25 +5 +30
180 Ah batteries	+14 +3 +17	+14 +3 +17	+14 +3 +17	+14 +3 +17	+14 +3 +17	+14 +3 +17	+14 +3 +17	+14 +3 +17	+14 +3 +17	+14 +3 +17	+14 +3 +17	+14 +3 +17
225 Ah batteries	+46 +10 +56	+46 +10 +56	+46 +10 +56	+46 +10 +56	+46 +10 +56	+46 +10 +56	+46 +10 +56	+46 +10 +56	+46 +10 +56	+46 +10 +56	+46 +10 +56	+46 +10 +56
Std tank-full	+131 +93 +224	+135 +89 +224	+138 +86 +224	+142 +82 +224	+145 +79 +224	+148 +76 +224	+150 +74 +224	+153 +71 +224	+155 +69 +224	+158 +66 +224	+160 +64 +224	+162 +62 +224
*1x450l G	+71 +100 +171	+75 +96 +171	+79 +92 +171	+83 +88 +171	+86 +85 +171	+89 +82 +171	+92 +79 +171	+95 +76 +171	+97 +74 +171	+100 +71 +171	+102 +69 +171	+104 +67 +171
EG Series PTOs	+26 +4 +30	+26 +4 +30	+26 +4 +30	+26 +4 +30	+26 +4 +30	+26 +4 +30	+26 +4 +30	+26 +4 +30	+26 +4 +30	+26 +4 +30	+26 +4 +30	+26 +4 +30

\* Additional to standard tank full of fuel.

### ENGINE PERFORMANCE

'230' DC9-39/30

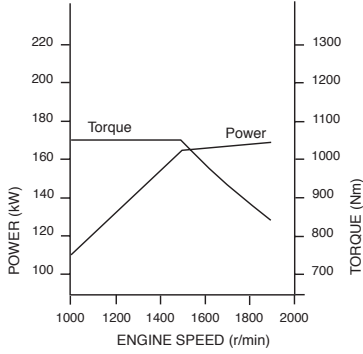

'280' DC9-38/29

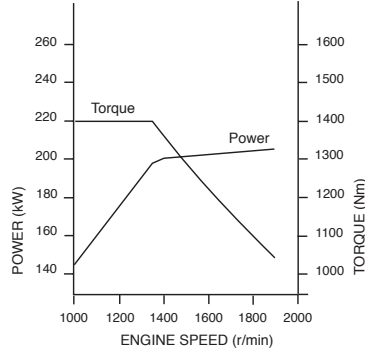

'320' DC9-37/32

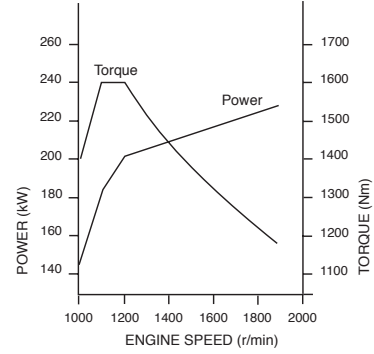

Net engine performance to 80/1269\*1999/99EC

### GEAR STEP DIAGRAM

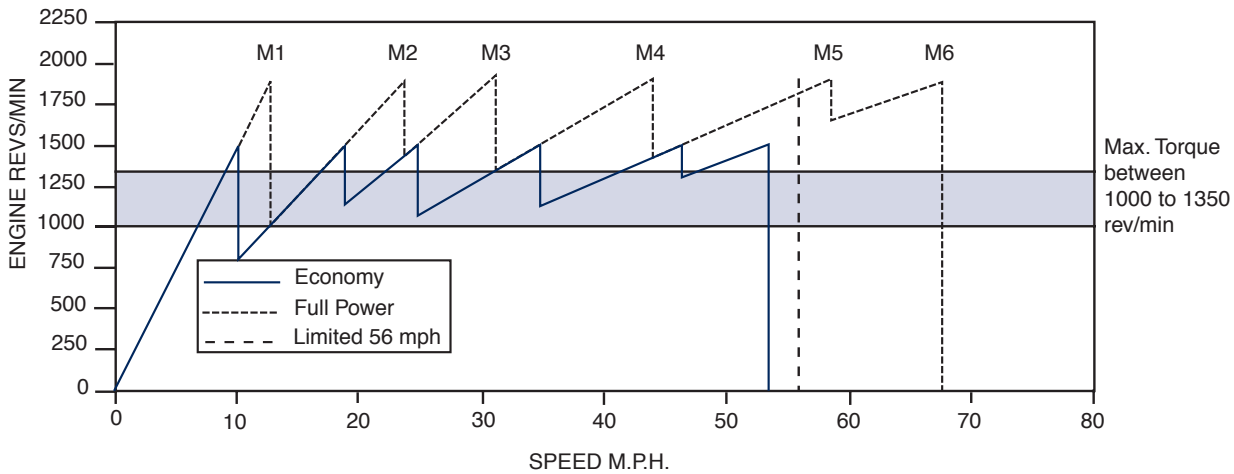

### SPEED/GRADEABILITY

Gradeability may be limited by tyre adhesion.

Axle gear/ Ratio	Optimum Cruising Speed M.P.H.	Gradeability - steady climb - in percent		
		DC9-39 26T	DC9-38 26T	DC9-37 26T
R 660 4.88	43-56	17.7	20.6	32.0
R 660 5.57 std.	38-50	19.7	23.2	>35

Calculations assume standard specifications. Performance achieved in operation will depend on conditions, bodywork, gear ratios and tyre specification.

The specifications contained in this publication are intended as a general guide, and not as representations as to the product described, nor as binding in detail.

