

SCANIA

SPECIFICATION

P-, G- and R-series

R 500 LA6x2/4MNA

60000Kg GTW

TWIN STEER TRACTOR

R

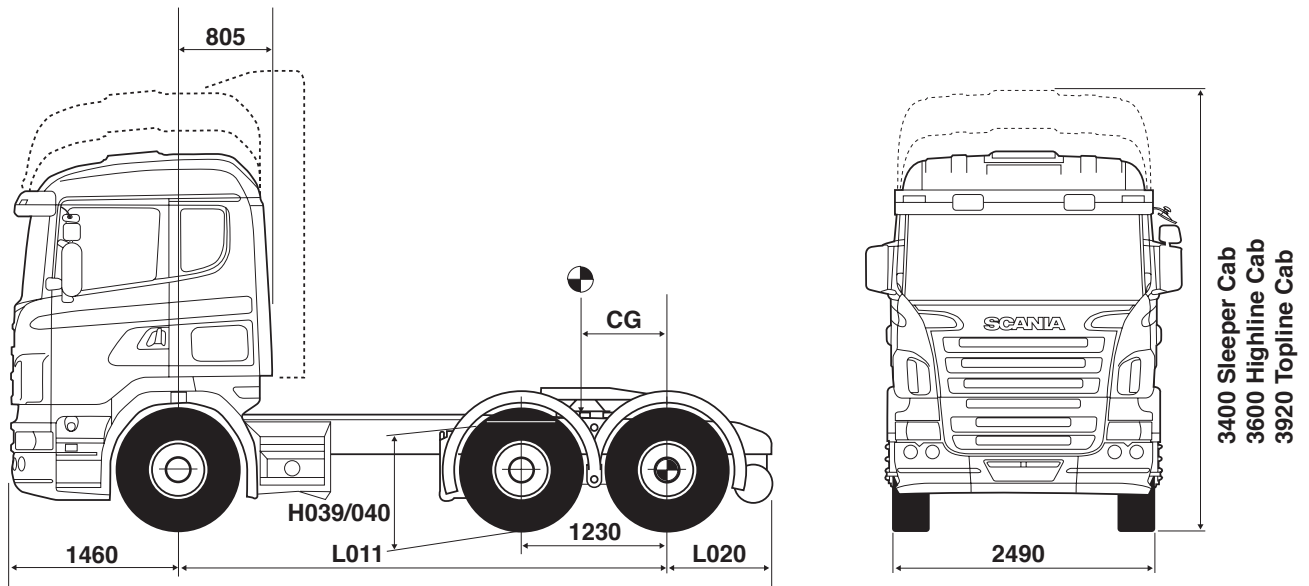

DIMENSIONS (mm)

L011		3975
L015		3515
L020		780
Sleeper Cab	CG	838
Fifth Wheel position to suit 16.5m overall length		935 forward of drive axle centre line (Max imposed load = 11540 kgs)

H039 unladen = 1000mm H040 laden = 970mm L015 = theoretical wheelbase

CG dimension for imposed load calculated for standard model at standard GB plated weights. This dimension can be varied to suit specific trailer swing clearances but may result in a reduction in imposed load. Height dimension measured to top of frame at rear bogie centreline

PLATED WEIGHTS – AWR

		Front Axle	Second Steer	Rear Axle	GW	GTW
Design						
Gross	Kg	7500†	6100	10200	23800	60000
Legal						
Max in GB	Kg	7100¶	6000	10000	23100	44000

† Front axle capacity up to a maximum of 8000 kg available as option.

¶ Legal front axle capacity limited by tyres.

Plated weights dependent on statutory tyre limitations.

CHASSIS/CAB WEIGHTS

(Tolerance +/- 2.5%)

Axle distance	Front	Bogie	Total (kg)
3975	5350	2920	8270

Chassis cab weight includes 20 litres of fuel, oil and water.

Driver not included. See overleaf for option weights.

R 500 LA6x2/4MNA

SL5451088
March 09

ENGINE (EURO 5)

Scania '16 litre' V8 turbocharged intercooled direct injection diesel with unit injectors.

	'500'
Type:	DC16-19
Swept Volume:	15.6 litres
Bore:	127 mm
Stroke:	154 mm
Compression Ratio:	17:1
*Max. Power:	368 kW (500 h.p.) at 1800 rev/min
*Max. Torque:	2500 Nm (1844 lbf.ft) between 1000 and 1350 rev/min

Engine Management System: EMS incorporating Cruise Control and speed limiter.

Emission control: Scania SCR.

Cooling: Water cooled with rubber mounted 2 row radiator and electronically regulated fan

Coolant Capacity: 76 litres

Oil Capacity: 38 litres

Air Cleaner: Dry replaceable paper element

Options:-

(1) Details as above except for the following:-

	'560'
Type:	DC16-18
*Max. Power:	412 kW (560 h.p.) at 1900 rev/min
*Max. Torque:	2700 Nm (1991 lbf.ft) between 1000 and 1400 rev/min

(2) Details as above except for the following:-

	'620'
Type:	DC16-17
*Max. Power:	456 kW (620 h.p.) at 1900 rev/min
*Max. Torque:	3000 Nm (2213 lbf.ft) between 1000 and 1400 rev/min

(3) Provision for ED160 engine driven P.T.O.

*With fan at max. slip

CLUTCH

Type: Single dry plate

Operation: Air assisted with clutch wear protection

GEARBOX

Type: Scania GRS0905 fourteen speed overdrive with synchromesh on all except two crawler gears. Incorporating range change and splitter. Oil cooler.

Oil Capacity: 15.6 litres

GEAR RATIOS

	Low Range Split		High Range Split	
	L	H	L	H
Crawler	13.28:1	10.63:1		
	9.16:1	7.33:1	2.44:1	1.96:1
	5.82:1	4.66:1	1.55:1	1.24:1
	3.75:1	3.00:1	1.00:1	0.80:1

Reverse 11.95:1

Options:-

(1) Type: Scania GRS905 fourteen speed range change/splitter including two crawler gears – '500' and '560' engines only.

(2) Opticruise: Gearchange management system.

REAR AXLES

Type: Second steer axle - Scania ARA820
Drive axle - Scania ADA 1100

Capacity: Combined 19000 Kg

Drive axle has pressed steel housing with magnetic oil drain plug.

REAR AXLE GEAR

Type: Scania R780

Single reduction hypoid. Crown wheel and pinion matched during manufacture. Pneumatically operated differential lock.

FRONT AXLE

Type: Scania AM740 I section rigid beam – AMA740 if air suspension

Capacity: 7500Kg

Options:-

(1) Scania AM950 – capacity 9000 kg.

(2) Scania AMA860 – air only – capacity 8000 kg.

STEERING

Type: Recirculating ball. Hydraulically assisted power steering

Steering wheel: Diameter 450mm. Lock to lock 4.9 turns

Turning circle: Kerb to kerb 3.975m A/D 14.48m

SUSPENSION

Type Front: Semi-elliptic parabolic springs with swinging shackles and threaded shackle pins. Anti-roll bar.

Type Rear: Second steer axle - quarter elliptic with air bellows (A) (2 bag) which may be evacuated from the cab to increase drive axle traction. Pneumatic mid-axle hoist. Drive axle - quarter elliptic with air bellows. Chassis height may be raised or lowered to assist loading. Double acting telescopic shock absorbers are fitted to all axles.

SPRING SIZE

	Front
Length:	1820mm
No. of leaves	2 x 32mm
Design Capacity	7500Kg

Options:-

(1) Air suspension on front axle – design capacity 7500 or 8000 kg.

(2) 3 x 29mm leaves – design capacity 8500 kg.

WHEELS & TYRES

8.25 x 22.5 ten stud spigot mounted disc wheels fitted with 295/80R22.5 radial tubeless tyres.

Options:-

(1) 9.00 x 22.5 wheels with 315/80R22.5 tyres

(2) 11.75 x 22.5 wheels with 385/65R22.5 or 385/55R22.5 tyres - front axle only

(3) Aluminium wheels – Machined or Polished surface finish

(4) Wheel embellishers – steering axle

(5) Tyre Pressure Monitoring (TPM)

FRAME

Type: F800-50

Flat top constant depth 'U' channel with riveted crossmembers

Sidemember Dimensions:

F800 - 270 x 90 x 8mm

Width over parallel section of frame = 770mm

Bumper: Aerodynamic incorporating FUP

Options:- (1) Side skirts, (2) Steel bumper – increases front overhang to 1510mm, (3) Centre tow pin – steel bumper only.

BRAKE SYSTEM

Type:	Ventilated disc brakes on all axles. Dual circuit, full air, EC brake system incorporating Category 1 ABS and Traction Control. Electronic signalling with pneumatic back-up. Pad wear indicator. Brake pipes manufactured from either rust protected steel or high impact synthetics
Service Circuit:	Actuates all tractor and trailer brakes
Secondary Circuit:	Actuates split service system plus trailer brakes
Parking Brake:	Actuates spring chambers on front and drive axles
Exhaust Brake:	Air actuated operated by brake pedal
Brake Antifreeze Protection:	Air dryer
Brake Wear Adjusters:	Automatic

Options:-

- (1) Scania Hydraulic Retarder
(2) ESP - Electronic stability programme

BRAKE DIMENSIONS

Pad lining area:	2 x 190cm ² on all axles
Swept area of each disc:	2 x 940cm ²

ELECTRICAL SYSTEM

Type:	24V neg (-ve) earth	Alternator:	100A
Batteries:	Twin 180 Ah		
Rear H.I. lamps, Reversing lights, Side marker lamps.			

Options:-

- (1) 140Ah batteries, (2) 225Ah batteries, (3) Battery connection – 200A,
(4) Bodywork electrical preparation – see separate document

FUEL TANKS

1 x 300 Litre LHS
AdBlue tank on RHS – capacity 75l with 'W' tanks.

Options:- (Minimum axle distance and suspension type in brackets)

	RH Side	LH Side
Aluminium - W	175	200 300

Tank sizes can be supplied in LH + RH combinations of the above. Sides viewed from rear.

GENERAL EQUIPMENT

Fixed 5th wheel - 285mm above frame
Lead-on ramps
Double Manwalk with step and coupling lamp
Rear Wings
Front tow pin

Options:-

- (1) Fifth wheel position in front of drive axle centre line - 635 to 1085mm in 50mm increments
(2) Sliding 5th wheel - 303mm above frame
(3) Vertical exhaust outlet – N/A with ADR to EXII/EXIII or FL
(4) ADR to EXII/EXIII, FL, OX or AT
(5) Adaptive Cruise Control (ACC) – retarder mandatory

INSTRUMENTS & CONTROLS

Two man, one day, EC digital tachograph, rev-counter and gauges for coolant temperature and fuel. Central display for vehicle information and warning messages. Six speed wipers with four jet integral screen wash. Halogen headlamps adjustable from cab for correction of beam height. Warning lights for all major systems grouped within easy vision.

Instrument panel of modular design with switches and controls grouped according to usage. All instruments are back-lit and non-reflective. Impact absorbing, adjustable steering wheel with column lock.

CAB

CR19 Sleeper Cab

Please see separate specification – 'Scania Cabs' for equipment levels.

Options:-

- (1) CR19 Highline
(2) CR19 Topline

P.T.O. OPTIONS Check gearbox availability

Rear Mount		G670	GR875 / GRS895 / GR/S905	GRS0905
Pump	Flange			
EG551P	EG561F	0.54		
EG650P	EG660F		1.00 / 1.24H	
EG651P	EG661F		1.28 / 1.58H	
EG652P	EG662F			0.82 / 1.03H
EG653P	EG663F			1.03 / 1.29H
EK730	EK740		1.00	1.00

H= High on 'S' splitter gearboxes only.
Flange output N/A on 6x2/4 chassis.

WEIGHTS FOR OPTIONAL EQUIPMENT IN KILOGRAMS (Front – Rear – Total)

Axle Distance	3975	
AdBlue tank full	+48	+34 +82
AM950 front axle	+13	0 +13
Air suspension front	+40	+15 +55
3 x 29mm front springs	+44	0 +44
315/80 tyres + 9.00x22.5 rims	+18	+54 +72
385/55 tyres + 11.75x22.5 rims	+46	N/A +46
385/65 tyres + 11.75x22.5 rims	+54	N/A +54
Aluminium Wheels		
8.25x22.5	-24	-72 -96
9.00x22.5	-30	-90 -120
11.75x22.5	-44	N/A -44
Side skirts	+20	+19 +39
FUP steel bumper	+67	-13 +54
Centre tow pin	+29	-5 +24
Retarder	+101	+20 +121
140Ah Batteries	-13	-4 -17
225Ah Batteries	+31	+8 +39
Std. Tank Full	+116	+118 +234
*1 x 300 + 1 x 175l W	+92	+80 +172
Sliding 5th wheel	+8	+52 +60
Vertical exhaust outlet	+37	+8 +45
CR16 (no deflectors)	-153	-14 -167
CR19 Highline Cab	+27	+2 +29
CR19 Topline Cab	+73	+6 +79
EG Series PTOs	+15	+3 +18
EK Series PTOs	+42	+5 +47

* Additional to standard tank full of fuel.

R 500 LA6x2/4MNA

ENGINE PERFORMANCE

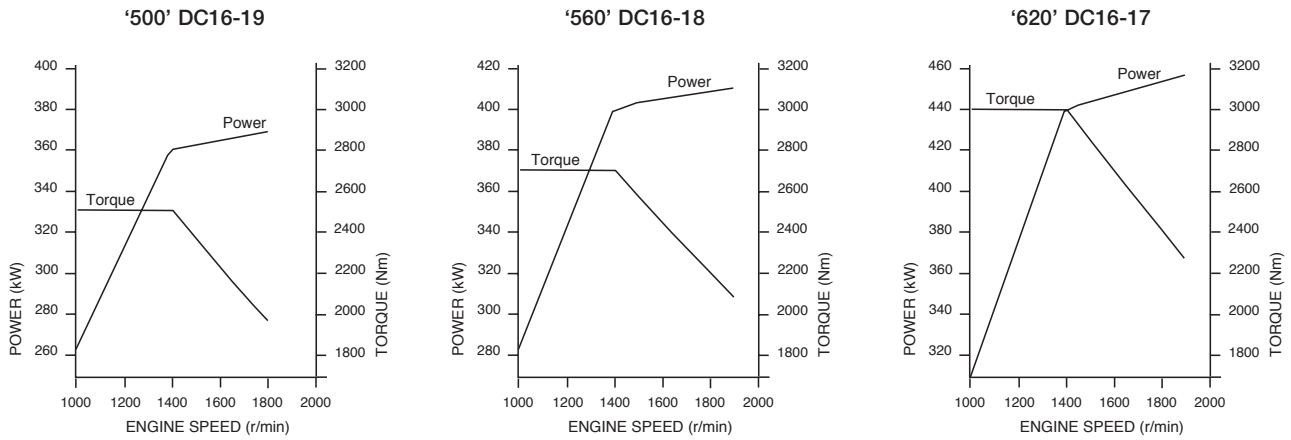

Net engine performance to 80/1269*1999/99EC

GEAR STEP DIAGRAM

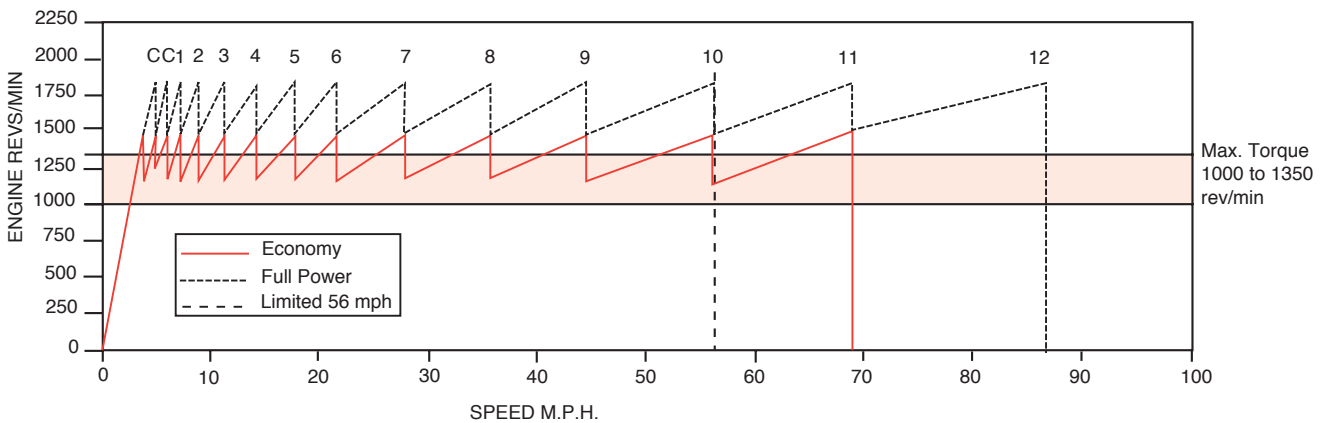

SPEED/GRADEABILITY Gradeability may be limited by tyre adhesion.

Axle gear/ Ratio	Geared Speed M.P.H.		Gradeability - steady climb - in percent					
	11th	12th	DC16-19		DC16-18		DC16-17	
			44T	60T	44T	60T	44T	60T
R 780 2.71*	69.4	86.8	>35	31.6	>35	34.4	>35	>35
R 780 2.92*	64.4	80.6	>35	34.3	>35	>35	>35	>35
R 780 3.08 Std	69.3	86.6	>35	31.6	>35	34.4	>35	>35
R 780 3.27	65.3	81.6	>35	33.8	>35	>35	>35	>35
R 780 3.42	62.8	78.5	>35	>35	>35	>35	>35	>35
R 780 3.80	56.2	70.2	>35	>35	>35	>35	>35	>35

*2.71 and 2.92 only available with low profile tyres. Calculations based on 295/60R22.5 rear tyres.

Remaining calculations assume standard specifications. Performance achieved in operation will depend on conditions, bodywork, gear ratios and tyre specification.

The specifications contained in this publication are intended as a general guide, and not as representations as to the product described, nor as binding in detail.

